

Chemical Reduction Solutions Ionization Enhanced Nanobubble Generator

THE SHAFT

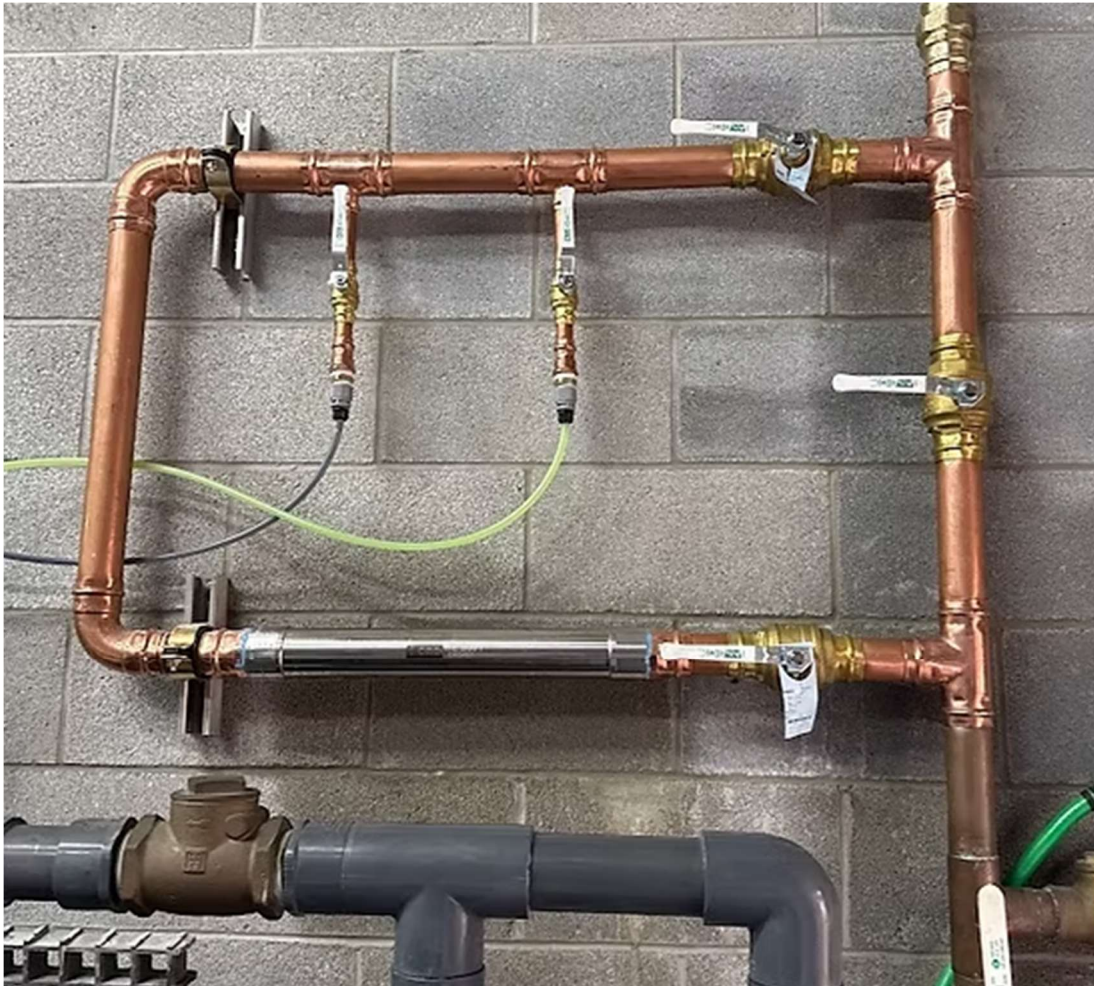

Please read and save these instructions.



General Safety Information

Icon Legend:

 — DANGER! ... Injury or death and property damage are imminent

 — WARNING! ... Injury or death and property damage are possible

 — CAUTION! ... Potential property damage, expensive repairs, and/or voiding the equipment warranty may result



BURN HAZARD! Direct exposure to steam, hot water, or hot metal surfaces can cause severe skin burns. Skin contact with 140°F (60°C) water or metal for only five (5) seconds may cause a second-degree burn.

Failure to comply with instructions following a safety icon may result in adverse consequences including, property damage, personal injury, or, in extreme cases, death.

General Safety Guidelines:

1. Inappropriate use of this product (beyond typical, intended use) could cause damage to the product and other property. It may also result in personal injury or, in extreme cases, death.
2. Only designated, qualified, and competent personnel should conduct installation, maintenance, and service in accordance with the directions in this product instruction manual.
3. Installation shall comply with all applicable federal, state, and local, electrical and construction, regulatory codes.
4. Improper installation, start-up, operation, maintenance, or service may void the product warranty.
5. When installing, commissioning or servicing this product:
 - a. ALWAYS select and wear appropriate personal protective equipment (PPE) before carrying out any physical work at the job site. Appropriate PPE may include hard hats, safety glasses, gloves, boots or shoes w/ non-slip soles and toe guards, and protective overalls.
 - b. ALWAYS scan the work area and take note of potential hazards before entering. Adjust your travel path or work position to avoid hazards and personal injury.
 - c. ALWAYS observe designated safety procedures when working in hazardous locations (areas containing explosive and combustible gases, vapors, and dusts) and confined spaces (locations where the breathable air supply may be limited or variable or where entrapment could occur).
 - d. ALWAYS use appropriate lockout-tagout procedures to disconnect power sources and de-energize machinery before conducting installation, service, and repair.
 - e. ALWAYS use great care and appropriate safety gear when working above ground level, especially on ladders and platforms or in the presence of overhead, electrical power lines.
 - f. ALWAYS ensure that all "live" steam, water supply, and condensate return lines are isolated before breaking or loosening any plumbing joints.
 - g. ALWAYS carefully relieve any residual internal pressure in the system or connecting pipe work before breaking or loosening any plumbing joints.
 - h. ALWAYS allow hot parts to cool before commencing work to avoid the risk of skin burns.

Table of Contents

1. Product Description	4
2. Applications	5
3. Product Operation	6
4. Product Installation	7
5. Application Schematics	7–10
6. What to Expect at Initial Startup	10
7. Installation, Validation and Ongoing Monitoring Protocols	11–12
Limited Warranty	13
Installation Examples	14

1. Product Description

The CRS Ionization Enhanced Nanobubble Generator (hereinafter referred to as the “Shaft”) is a proven solution for reducing the surface tension of water, improving chemical mixing, increasing dissolved oxygen levels, removing biofilm from membranes, removing and preventing the buildup of scale and biofilm, preventing nozzles and fixtures from clogging from scale and biofilm, cleaning with reduced chemical use, turbo-charging biological wastewater processes and enhancing UV and ozone applications. This patented technology is easily installed, has no moving parts, requires no maintenance or additional electrical inputs, and uses no chemicals. The Shaft can be installed with or without gas injection depending on intended use.

Product	Min Flow Rate	Max Flow Rate	Material	Fittings	Approx Weight of Generator	Length of Generator
CRS03	6 GPH	180 GPH	316 Stainless Steel + Ionizing Alloy Core	1/2" Female Threaded	<1lb	4"
CRS15	1.5 GPM	5 GPM	316 Stainless Steel + Ionizing Alloy Core	1/2" Female Threaded	<1lb	5.25"
CRS39	3 GPM	9 GPM	316 Stainless Steel + Ionizing Alloy Core	3/4" Female Threaded	1.25lb	7.5"
CRS614	6 GPM	14 GPM	316 Stainless Steel + Ionizing Alloy Core	3/4" Female Threaded	1.5lb	10"
CRS1020	10 GPM	20 GPM	316 Stainless Steel + Ionizing Alloy Core	1" Female Threaded	2.0lb	12"
CRS1525	15 GPM	25 GPM	316 Stainless Steel + Ionizing Alloy Core	2" Female Threaded	5.0lb	14"
CRS2040	20 GPM	40 GPM	316 Stainless Steel + Ionizing Alloy Core	2" Female Threaded	6.5lb	17.5"
CRS4090	40 GPM	90 GPM	316 Stainless Steel + Ionizing Alloy Core	2" Female Threaded	8.1lb	19.5"
CRS3487 (PVC)	40 GPM	90 GPM	Schedule 80 PVC + Ionizing Alloy Core	2" Female	10lb	18"
CRS5309	75 GPM	120 GPM	316 Stainless Steel + Ionizing Alloy Core	2" Flange	24lb	20"
CRS7925	90GPM	210 GPM	316 Stainless Steel + Ionizing Alloy Core	3" Flange	28lb	21"
CRS14265	210 GPM	370 GPM	316 Stainless Steel + Ionizing Alloy Core	4" Flange	45lb	22"
CRS25000	370 GPM	650 GPM	316 Stainless Steel + Ionizing Alloy Core	5" Flange	66lb	22"
CRS45000	650 GPM	925 GPM	316 Stainless Steel + Ionizing Alloy Core	6" Flange	79lb	22"
CRS63000	925 GPM	1,300 GPM	316 Stainless Steel + Ionizing Alloy Core	8" Flange	152lb	24"
CRS85500	1,300 GPM	1,700 GPM	316 Stainless Steel + Ionizing Alloy Core	10" Flange	200lb	38"
CRS2500	20 GPM	60 GPM	316 Stainless Steel + Ionizing Alloy Core (note not for single pass applications)	2" Female Threaded	5lb	12"
CRS5500	40 GPM	120 GPM	316 Stainless Steel + Ionizing Alloy Core (note not for single pass applications)	2" Female Threaded	6lb	12"

Designs, materials, weights and performance ratings are approximate and subject to change without notice. Visit chemicalreduction.com for up-to-date information.

2. Applications

Standard applications include but are not limited to the following:

- Car Washes (both on the fresh water side and the reclaim side)
- Irrigation
- Open Condenser Water Systems; Closed Loop Hydronic Water Systems (Heating and Cooling); Domestic Hot Water
- Water Used for Cleaning
- Pool Systems

All applications—including those listed and not listed here—should be assessed by an appropriate engineer prior to installation. Questions regarding CRS or nanobubble generator installation should be directed to www.chemicalreduction.com.

3. Product Operation

Once installed in the correct place, the CRS Shaft will work to generate nanobubbles and charged particles as soon as water begins to flow through it at a sufficient flow rate. The minimum flow rate shown in the chart above is the minimum flow needed for the device to work. The maximum flow rate is merely a suggestion to avoid materially restricting flow.

Sizing Guidelines

Commercial Real Estate:

DHW with recirculation—Shaft target flow rate—100% of recirc. Maintain target flow above 75% of recirc.

Hydronic heating and chilled water closed loop systems—Shaft target flow rate—10% of total system pumping flow rate. Adjust target flow up if needed.

Cooling tower condenser water system—Shaft target flow rate-5% of total system pumping flow rate. Adjust target flow up if needed.

Cooling towers used for industrial process cooling can have a much longer turnover rate. Shaft target flow rate should turn total system volume over in 4–6hrs max.

Car Washes (Fresh Water and Reclaim):

Feed line to RO generator – Shaft should be sized such that minimum flow is achieved and maximum flow is not restricting peak use. For example, if a wash typically uses 6-8GPM of RO water and peak usage is 14-15GPM, a CRS614 is the correct size unit.

Feed line to chemistry – For a busy wash that usually has multiple nozzles open at any given time, the Shaft should be sized to the average flow into the chemistry dispensing system. If the wash is not busy or there are significant periods of reduced operational volume, then there should be a Shaft on each nozzle sized to the correct flow rate.

Reclaim (Gas Injection) – For reclaim applications, in order to maximize gas transfer (whether it be oxygen, air or ozone) the gas flow should be between 1-10% in LPM of the water flow in GPM. For instance, an appropriate gas flow could be 6LPM of oxygen through a CRS3487PVC running at 72GPM of water flow. Important to note, gas injection should be done prior to the Shaft but as far away as practicable to give the injected gas an opportunity to entrain in the water prior to flowing through the Shaft. For example, an oxygen injector located 20 feet upstream of the Shaft will result in very efficient oxygen nanobubble generation and the ability to increase dissolved oxygen to level once thought physically impossible. Alternatively, a manifold may be used that has at least one 90 degree elbow between the gas injection point and the Shaft. In order to determine the maximum flow of gas, use a clear PVC piece after the Shaft and turn the gas down until no visible bubbles are present in the flow of water after the Shaft. That level is peak gas transfer gas flow for such water flow.

Pools:

Size Shaft to generate nanobubbles both during the normal run cycle (i.e., with pump at 50% power) AND at peak turbo clean times. The CRS5500 (Pool) was specifically designed with a very wide flow band to accommodate most pools (i.e., 40-120GPM).

If injecting oxygen or ozone gas into the Shaft for a pool application, gas injection should be done prior to the Shaft and NOT directly prior to the Shaft to give the injected gas an opportunity to entrain in the water prior to flowing through the Shaft. A manifold may be used that has at least one 90 degree elbow between the gas injection point and the Shaft. In order to determine the maximum flow of gas, use a clear PVC piece after the Shaft and turn the gas down until no visible bubbles are present in the flow of water after the Shaft. That level is peak gas transfer gas flow for such water flow.

4. Product Installation

The following instructions can be used as guidance for the installation of a patent pending CRS nanobubble generator. Sizes range from less than 1 GPM to 1,000+ GPM with inline or sidestream application. Applications and systems will vary and should be reviewed by experienced personnel prior to installation. A licensed mechanical contractor should perform the installation.

Installing a Generator

1. Determine flow rate and existing pump capabilities OR calculate system volume and determine turnover rate, OR install a small recirculation pump and Shaft to recirculate.
2. Analyze increased pressure drop effect on system if installed in an existing system.
3. Select appropriate generator and pipe sizing.
4. Drain enough of the system to install tees and valves if using a side stream (see diagram below).
5. Install properly sized generator and piping (full or side stream).
6. Start pump or otherwise resume flow.
7. Open generator isolation valves, if applicable.
8. Shut off by-pass or balance to proper flow rate through generator, if applicable.
9. Re-balance system, if necessary.
10. Monitor system for proper operation to maximize Shaft effect.

5. Application Schematics (Examples)

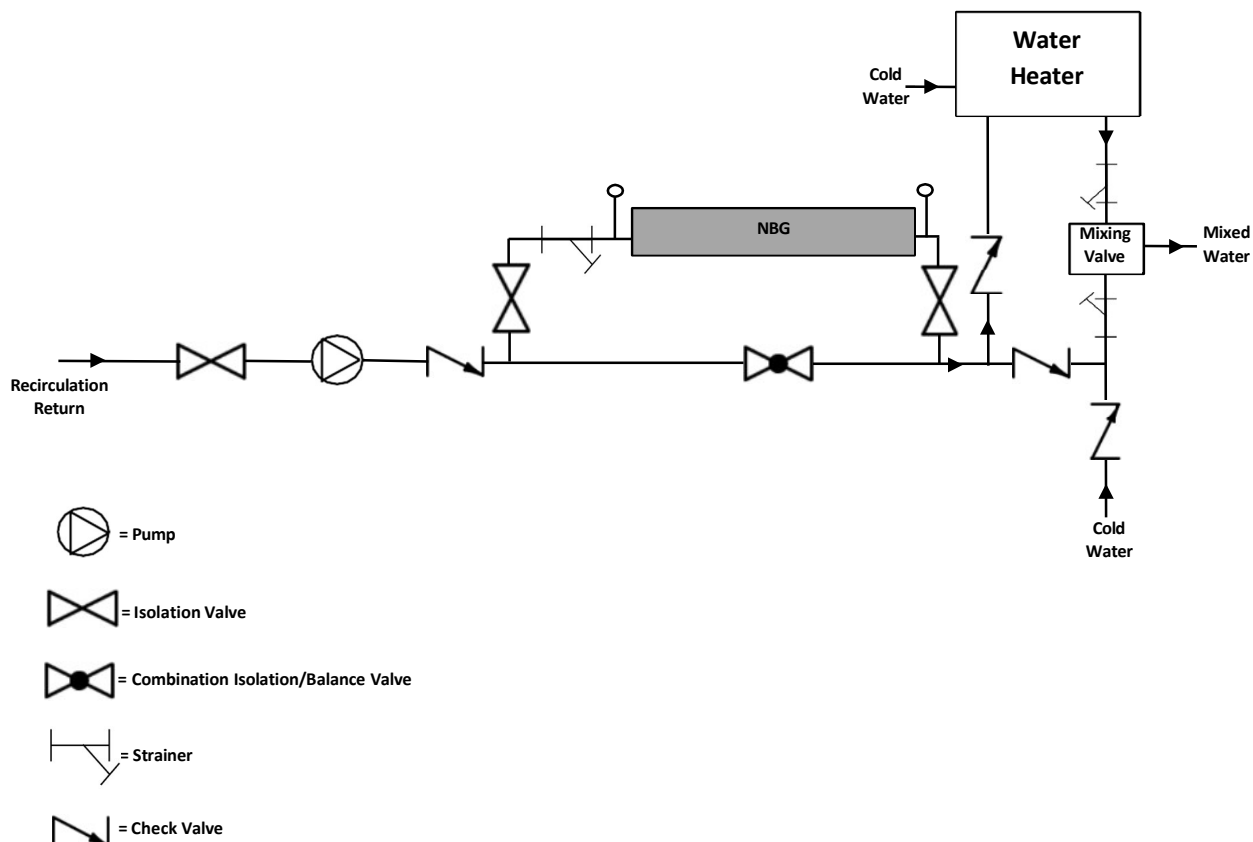

5. Application Schematics – continued

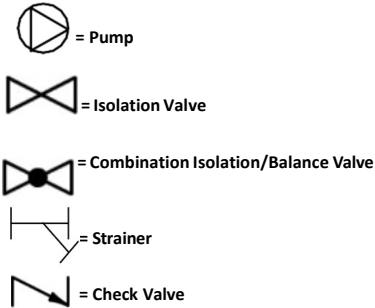
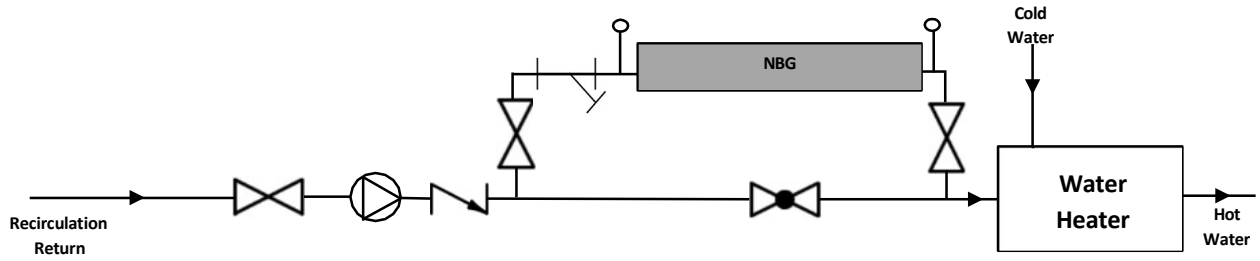

Recirculation w/o Mixing Valve

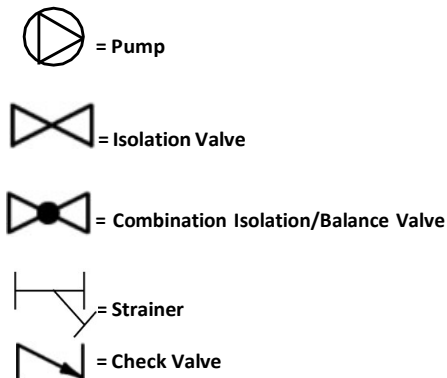
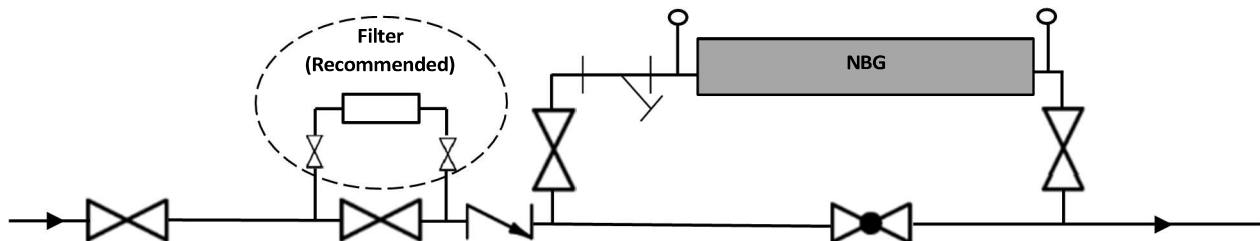

Single Pass

Designs, materials, weights and performance ratings are approximate and subject to change without notice. Visit chemicalreduction.com for up-to-date information.

5. Application Schematics – continued

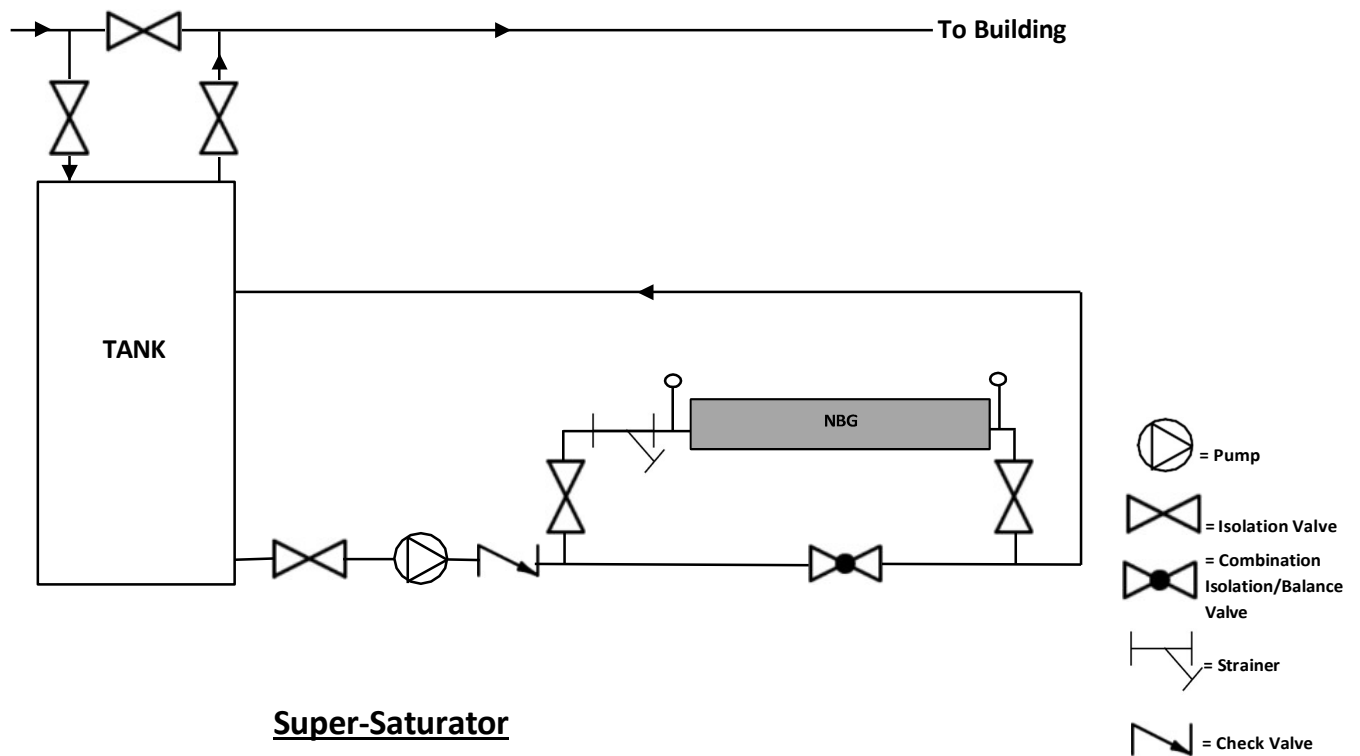

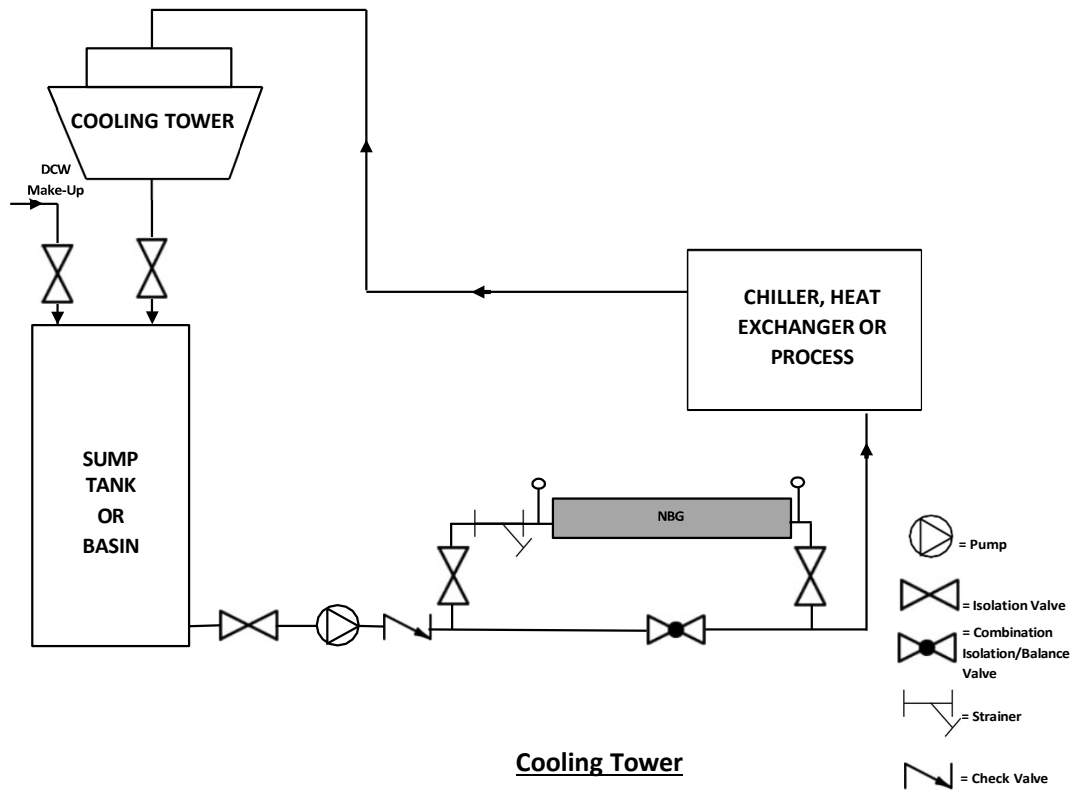

6. What to Expect at Initial Startup

Within a few hours after installation and initial startup, depending on the age of the system, the existing pipework and water quality, the system may discharge discolored water with minor debris. This is normal and part of the startup process and will flush out with time which is why complete system flushing (not just blowing down strainers, remove the baskets as well) is critical after initial startup.

Installing the Shaft in a sidestream method (as shown in all of the prior schematics) allows the system to be balanced and adjusted for this initial startup period whereas the Shaft can be gradually brought on-line while purging the system until complete system saturation occurs. If the Shaft installed inline, the purging process will be more abrupt and operational considerations should be taken into account prior to installation.

7. Installation, Validation, & Ongoing Monitoring Protocols

Key References – WICRA (Water Infection Control Risk Assessment), TJC (The Joint Commission), TIR 34 (Technical Information Report), AAMI ST79 (Association for the Advancement of Medical Instrumentation), WMP (Facility Water Management Plan), NSF/ANSI 61 (National Science Foundation/ American National Standards Institute), Water Infection Control Risk Assessment (WICRA).

1. Planning Phase

a. The Facility shall develop a water sampling, testing, flushing, and ongoing monitoring (STFM) plan before installation of the Shaft which will be followed throughout the installation, start-up, and post-install monitoring time. The Facility shall recommend a third-party review of the STFM for sufficiency. Elements of this plan are as follows:

1. Review current water systems testing, monitoring, and treatment plan, including existing WICRA and WMP, for a compatible and complimentary overall strategy for the affected portion(s) of the Facility. Additional testing, monitoring, flushing and treatment may be added to existing WMP based on a Shaft risk assessment.
2. The Facility may perform its own Shaft risk assessment for systems that could be affected to inform the installation, validation, and ongoing monitoring phases. For example, collection points of biofilm debris, e.g., aerators, water hammer arrestors, and in-line filters, including integral filters, e.g., integral biofilters in disinfection-type medical equipment or ice machines, which are not easily cleaned by flushing.
3. The Facility should conduct baseline microbial sampling and water quality testing at control points per the Facility's WMP. Additional locations could be added as determined by the Shaft risk assessment, part 1.a.2 above.
 - i. Microbial sampling should include Total CFU (colony forming units, bacterial and fungal), or Heterotrophic Plate Counts (HPC), and can include more specific total coliform quantification as per EPA drinking water standard (<200cfu/ml). (In critical environments, testing for species of pathogenic microorganisms, such as Mycobacterium, and Pseudomonas can be added).
 - ii. Biofilm marker testing can include Total Organic Carbon (TOC) and/or Total Protein (Wilson C et.al 2017)
 - iii. Endotoxin testing is recommended as a pre-installation baseline, post installation and during the flushing stage. Routine endotoxin testing is not recommended as per the EPA drinking water recommendations.
 - iv. Rapid ATP (Adenosine Triphosphate) water testing can be conducted on-site as a screening tool for ongoing monitoring. Baseline should be established before and after installation (Wilson C et.al 2017).

v. Other water quality testing can include hardness (<150mg/L tap; <1mg/L critical), conductivity (<500mS/cm tap; <10mS/cm critical), pH (6-9 tap; 5-7 critical), chlorides (<250mg/L tap; <1mg/L critical). (AMI Guide TIR34:2014/R(17), Section 4).

4. As part of the planning phase, the Facility should assess the need for strainers and filters installed and maintained by the Facility during start-up and ongoing if desired. See 2.a below.

2. Installation Phase

- a. The Facility shall install an in-line strainer (type and size may vary with a screen mesh of 40 as a good rule of thumb) upstream of the nanobubble water treatment device and routine cleaning should be included in the Facility's maintenance schedule.
- b. The Facility may choose to install filters to protect distal points per the STFM. Include routine inspection and cleaning in the Facility's maintenance schedule.
- c. The Facility shall flush the system upon start-up of the Shaft. The Facility should continue following the flushing protocol per their WMP or updated WMP that includes Shaft protocols, see 1.a.i above. Note: if the protocol has a rotation of flushing distal points (not all performed on the same unit of time), supplemental testing of the system served by the Shaft should be added.
- d. The Facility shall conduct microbial sampling and water quality testing at control points per the STFM and the Facility's WMP and/or updated Shaft WMP.

3. Validation Phase

- a. The validation phase serves to independently ensure the safety of the water treated by the Shaft as compared to baseline, and to validate the efficacy of the Shaft in improving water quality for the Facility.
- b. If Facility chooses to do so; A third party shall conduct and/or oversee microbial sampling and/or water quality testing at control points per part 1.a.iii above. The testing may be conducted by the facility maintenance personnel defined in the WMP (the WMP or updated Shaft WMP must include training of Facility maintenance personnel who will be responsible for sample collection, proper handling (sterility, temperature, holding time and transportation of samples, as well as PPE) if applicable).
- c. The third party shall receive, analyze, and report the independent laboratory data to the Facility.
- d. Once validation of the system has been achieved and safety and efficacy have been approved, validated water quality may serve as the new baseline for ongoing monitoring, see below.
- e. After the Shaft efficacy is validated, the Facility shall update maintenance and cleaning schedules in the WMP to reflect the needs of the new system addition.

4. Ongoing Monitoring Phase

- a. The purpose of the ongoing monitoring phase is to ensure the achieved Shaft water quality improvements and/or validated baselines, are maintained.
- b. The ongoing monitoring phase should be conducted or overseen by a third party, and should include control limits, control measures, corrective actions, and contingency response per the STFM and the Facility's WMP and/or updated Shaft WMP.
- c. As with the validation phase, trained Facility maintenance personnel may collect samples. Independent laboratory data receipt, analysis, interpretation, and reporting are the responsibility of the third-party consultant. Recommendations for corrective actions are the responsibility of the third-party consultant. Implementation of the corrective actions are the responsibility of the Facility.
- d. Validation of corrective actions should follow the validation phase as per 3.a-d above, prior to resuming ongoing monitoring.

Definitions:

Biofilm: Densely packed communities of microbial cells that grow on living or inert surfaces and surround themselves with secreted polymers.

Building water systems: Includes hot and cold-water distribution and all devices that use water. This can include items, such as hot tubs, decorative fountains, and cooling towers.

Control: To manage the conditions within your building according to your water management program.

Building Water Management Program (WMP): a facility or system policy prescribing controls, control limits, control measures, and control points, contingency response, and corrective actions to maintain acceptable levels to protect patients, team members, and visitors from water borne pathogens.

Control limits: The maximum value, minimum value, or range of values that are acceptable for the control measures that you are monitoring to reduce the risk for Waterborne pathogens growth and spread.

Control measures: Engineering controls and practices you implement in your building water system to limit growth and spread of Waterborne pathogens, such as heating, adding disinfectant, or cleaning.

Control points: Distal points in the water systems where a control measure can be applied.

Contingency response: Reaction to control measures that are persistently outside of control limits or events that pose an immediate risk to control of your building water systems; required for all instances when Legionnaires' disease occurs, but may also be appropriate for unexpected events such as equipment failure or acts of nature that disrupt the water system.

Corrective action: Steps taken to return control measures to acceptable levels.

Dead legs: Piping that is subject to low or no flow due to design or decreased water use such as capped pipes or unused faucets.

Disinfectant: Chemical or physical treatment used to kill germs, such as chlorine, monochloramine, chlorine dioxide, copper-silver ionization, ultraviolet light, or ozone.

Distal point: a location near the end of a distribution system branch where water is dispensed, and potential stagnation can occur based on usage.

Filtering: Removes small contaminants that may pass through a strainer.

Hazardous conditions: Anything that, if not controlled, can contribute to the growth, and spread of water borne pathogens to a person.

Heterotrophic plate counts: A measure of the number and variety of bacteria that are common in water; a high count may indicate a high microbial load and the need for corrective action but cannot be substituted for Waterborne pathogens testing.

Waterborne pathogens: Bacteria of fungal genus which encompasses species that can cause disease.

IOM: Installation, Operation, and Maintenance manual

PPE: Personal Protective Equipment

Residual: The amount of disinfectant available in water to kill microbes

Scale and sediment: The mineral build-up in a water system that uses up disinfectant and supports microbial growth and/or survival.

Stagnation: When water does not flow well, areas of stagnant water encourage biofilm growth and reduce temperature and level of disinfectant.

Straining: Removes larger contaminants and smaller contaminants may pass through.

Water Infection Control Risk Assessment (WICRA): CDC's risk assessment tool for water systems in facilities designed to prevent water borne pathogen exposure. This risk assessment may recommend and provide details to be included in the Facility's WMP.

Limited Warranty and Remedy

Chemical Reduction Solutions LLC (“CRS”) warrants to the original user of those products supplied by it and used in the service and in the manner for which they are intended, that such products shall be free from defects in material and workmanship for a period of five (5) years from the date of installation, [unless a Special Warranty Period applies, as listed below]. This warranty does not extend to any product that has been subject to misuse, neglect or alteration after shipment from the CRS factory. Except as may be expressly provided in a written agreement between CRS and the user, which is signed by both parties, **CRS DOES NOT MAKE ANY OTHER REPRESENTATIONS OR WARRANTIES, EXPRESS OR IMPLIED, INCLUDING, BUT NOT LIMITED TO, ANY IMPLIED WARRANTY OF MERCHANTABILITY OR ANY IMPLIED WARRANTY OF FITNESS FOR A PARTICULAR PURPOSE.**

The sole and exclusive remedy with respect to the above limited warranty or with respect to any other claim relating to the products or to defects or any condition or use of the products supplied by CRS, however caused, and whether such claim is based upon warranty, contract, negligence, strict liability, or any other basis or theory, is limited to CRS’s repair or replacement of the part or product, excluding any labor or any other cost to remove or install said part or product, or at CRS’s option, to repayment of the purchase price. As a condition of enforcing any rights or remedies relating to CRS products, notice of any warranty or other claim relating to the products must be given in writing to CRS: (i) within 30 days of last day of the applicable warranty period, or (ii) within 30 days of the date of the manifestation of the condition or occurrence giving rise to the claim, whichever is earlier. **IN NO EVENT SHALL CRS BE LIABLE FOR SPECIAL, DIRECT, INDIRECT, INCIDENTAL OR CONSEQUENTIAL DAMAGES, INCLUDING, BUT NOT LIMITED TO, LOSS OF USE OR PROFITS OR INTERRUPTION OF BUSINESS.** The Limited Warranty and Remedy terms herein apply notwithstanding any contrary terms in any purchase order or form submitted or issued by any user, purchaser, or third party and all such contrary terms shall be deemed rejected by CRS.

Design, materials, weights, and performance ratings subject to change without notice.
Visit chemicalreduction.com for the most up-to-date information.



Chemical Reduction Solutions LLC
chemicalreduction.com

Installation Examples



Shaft on Boiler Makeup Line



Shaft on submersible pump

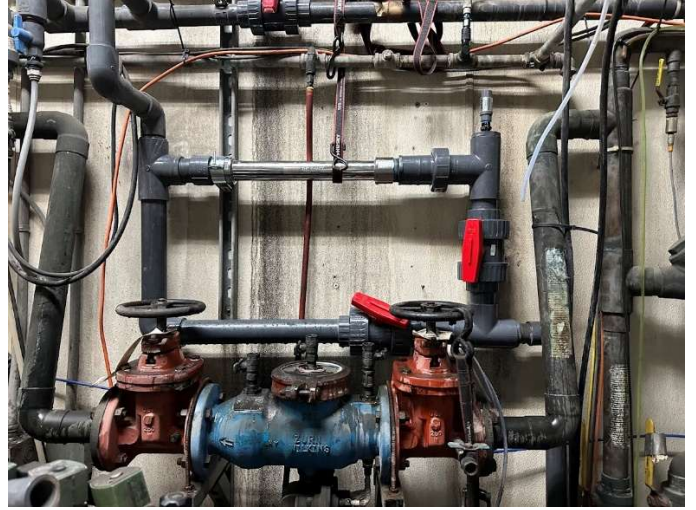

Shaft on a reclaim line installed side stream



Shaft on car wash chemical dispensing system



Shaft on swimming pool

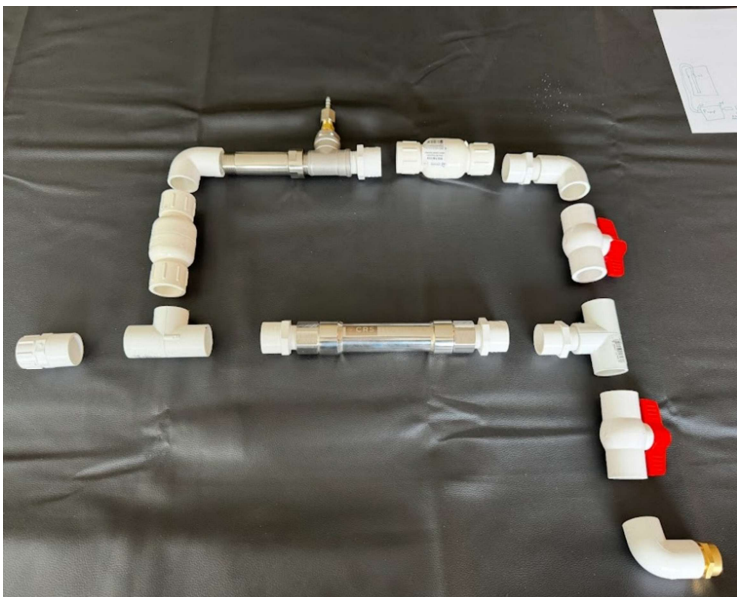

Pipe diagram of efficient gas injection manifold